

RESTRICTED VENDOR - VENDOR MUST BE USED FOR THE PURCHASE AND FABRICATION OF THE PART OR ASSEMBLY DUE TO LEGAL RESTRICTIONS SUCH AS INTELLECTUAL PROPERTY, OR CONTRACTUAL AGREEMENTS. NOTE: REBUILD OF RESTRICTED VENDOR ASSEMBLIES REQUIRES SPECIAL CONSIDERATIONS. IF NEW PARTS ARE REQUIRED THAT ARE CLASSIFIED AS "RESTRICTED VENDOR" THEMSELVES, OR IF P&G IS NOT GIVEN ACCESS TO DETAILED DRAWINGS OF THE REQUIRED PARTS FOR IIP REASONS, THE RESTRICTED VENDOR MUST BE CONTACTED FOR SUPPORT. ALL OTHER REBUILD ACTIVITIES INCLUDING ASSEMBLY, DISASSEMBLY, AND REPLACEMENT OF COMMERCIALY AVAILABLE AND NON-RESTRICTED VENDOR PARTS CAN BE EXECUTED BY P&G RESOURCES.

VENDOR:
 FAMECCANICA.DATA
 VIA ATERNO 136 - 66020 SAMBUCETO DI
 S. GIOVANNI TEATINO (CH) ITALY
 WWW.FAMECCANICA.COM

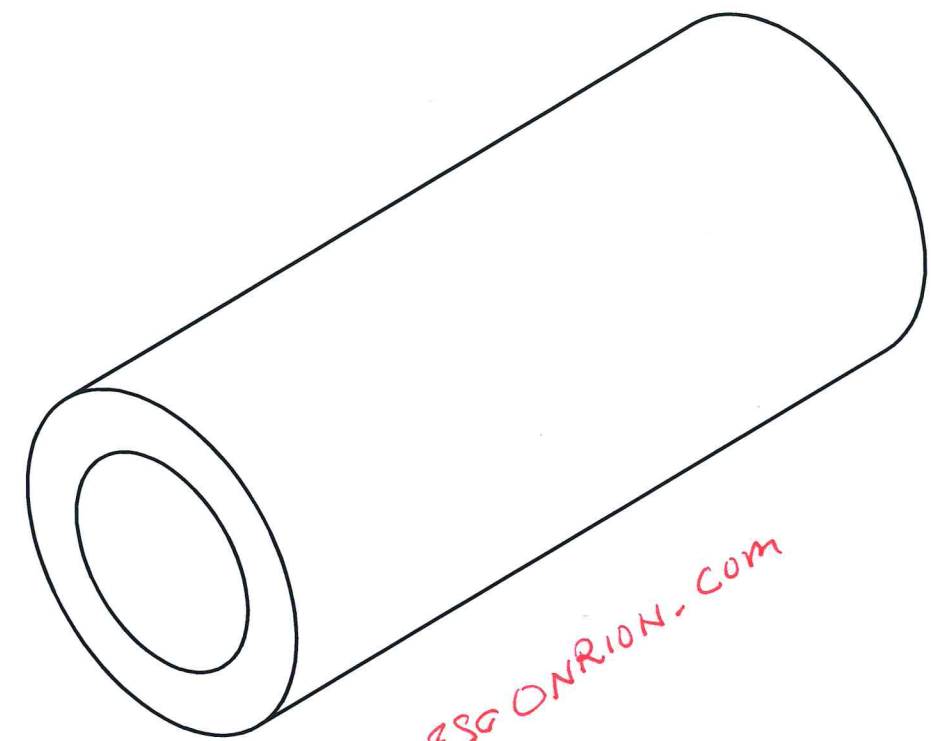
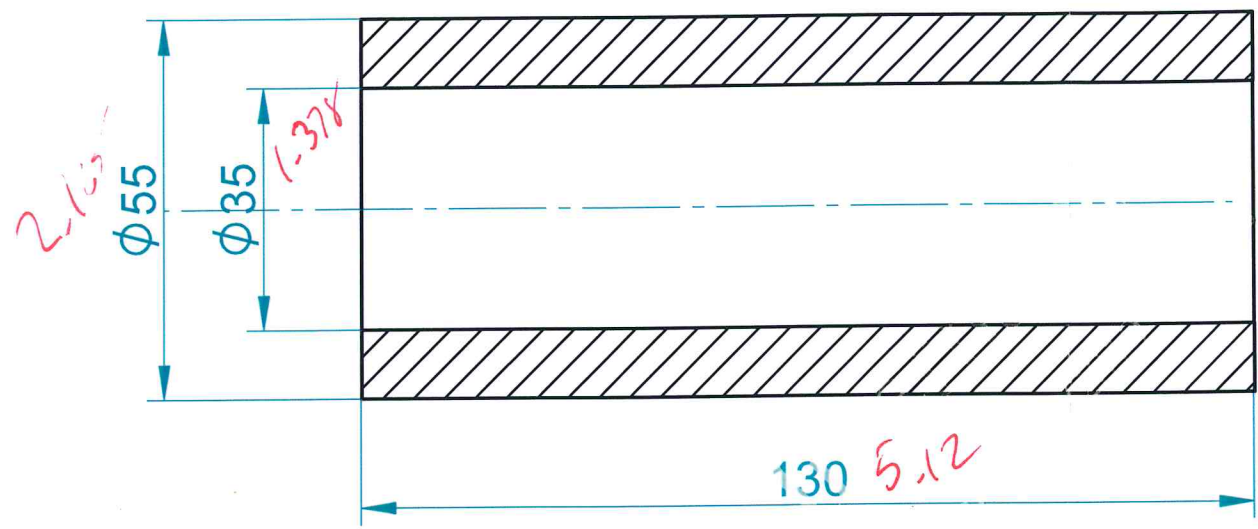

MATERIAL: CELLASTO MH24-40

Tolerance: Nach DIN 7715-M4

Supplier: Franz Stichling
 LINDENSTR. 87-A D-53721 SIEGBURG
 TEL.02241-50098 FAX.02241-55038
 GERMANY

Drawing Number Prefix Designation
 PA = P&G assembly drawing
 PG = P&G component drawing
 PV = Vendor drawing which P&G owns, controls, and/or has change rights
 VP = Vendor drawing which P&G does not own, control or have change rights

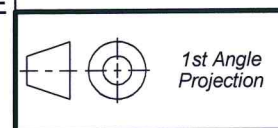

Material Weight in kg 0
 SEE DRAWING
 Stock Size

Last 5 Changes		
No	Explanation Summary	Name / Date

Property of Procter & Gamble - Important - This Drawing Print is loaned for mutual assistance and as such is subject to recall at any time. Information contained hereon is not to be disclosed or reproduced in any form for the benefit of parties other than necessary subcontractors and suppliers without written consent of Procter & Gamble.

Presentation	DETAIL	Scale	5:1
CAD System	SOLID EDGE	Drawing Size	A3

Title
**ROLL, OILER 55MMOD
 130MML**

Unless Otherwise Specified: All Dimensions in Millimeters(mm). Break All Sharp Corners. Surface Finish According To ISO 1302.

Default Tolerances								
Length	± 0.1	± 0.2	± 0.3	± 0.5	± 0.8	± 1.2	± 2	
Radius/Chamfer	± 0.2	± 0.5	± 1					
Angle	± 1	± 0.5	± 0.3	± 0.2	± 0.1			
From	0.5	3	6	30	120	400	1000	2000
Up To	3	6	30	120	400	1000	2000	4000

Design Site		Drawn	02/21/19	TAYLOR.JT
MMR No.	N	Check		
		Approv		
		Lead Designer		
Derived From		Project Owner		
Replaces		Project	19NA001-W1	
Printed By		Procter & Gamble		
Print Date		© 2019		
Ref Number				

Drawing Number
PG-6420011-R00
 Sht 1
 1 Shts