

Ultramat®

UFM-D30 / UFM-D30HP / UFM-D130



Condensate drain without compressed air loss

Product description:

The UFM-D's are compressed air zero-loss, electronically controlled condensate drains.

The large internal cross-sections for draining ensure reliable operation even when dealing with dirty, particle polluted condensate:

Less downtime, less trouble and more safety for the application - especially in direct comparison with time- or float controlled drains.

Additionally the condensate becomes less emulsified – when compared with time controlled solenoid valves. Less emulsification and better function of oil/water separators: longer compliance with legal discharge limits, less running costs!

As there is no air-loss whilst purging these drains work silent – a very important feature when this drain is installed within a working area!

The electronic control of the drain monitors the proper operation continuously. Automatic malfunction routines and a potential free contact for remote control ensures safe operation at all times. You can react to malfunctions before they are obvious by condensate water in the compressed air line at the point of use!

Applications:

Compressed air zero-loss draining of condensate at:

- compressors
- aftercoolers
- receiver-vessels
- pre- and after-filters of fridge dryers
- pre-filters of adsorption dryers
- condensate- and oil-removal filters
- pipe bends



Features:	Benefits:
Electronically level-controlled	No expensive compressed air losses, condensate drain depending upon resulting condensate amount, sensor detects each kind of condensate (also pure oil), also in case of strong contamination the draining works problem-free
Electronic control	Permanent function control via LED display, automatic emergency programs in the alarm mode, potential-free alarm contact function test via test button
Generously dimensioned cross sections	Easy maintenance, small inclination to emulsification, small noise during draining procedure, insensitive to dirt
Materials corrosion resistant	Aluminum corrosion-resistant, glass-fiber reinforced plastics steadily against oil-contaminated and oil-free condensate (special equipments for particularly aggressive condensate available)
Condensate inlet vertically or horizontal	Flexible and easy montage on different pipings possible

Materials:	
Housing	Aluminium, KTL coated

Potential free contact:	
Connection data AC	< 250 V / < 1A
Connection data DC	> 5 VDC / > 10 mA

Option:	
Heater	24 V; 115 V; 230 V
Insulation cover	
Bracket	

Technical Data	D30	D30HP	D130
min./max. operating pressure	0,8 - 16 bar (12-230 psi)	0,8 - 40 bar (12-580 psi)	0,8 - 16 bar (12-230 psi)
min./max. temperature	+1°C / +65°C (+34°F / +149°F)		
Condensate inlet	2 x G 1/2 (1/2")		3 x G 3/4 (3/4")
Condensate outlet	G 1/2 - a (di = 13 mm / 1/2")	G 3/8 - i	G 1/2 - a (di = 13 mm / 1/2")
Condensate	oil contaminated + oil free		
Weight (empty)	2,0 kg (4.4 lbs)		2,9 kg (6.4 lbs)
max. compressor performance ¹⁾	30 m ³ /min (1,060 scfm)		130 m ³ /min (4,590)
max. fridge dryer performance ¹⁾	60 m ³ /min (2,120 scfm)		260 m ³ /min (9,180 scfm)
max. filter performance ¹⁾	300 m ³ /min (10,600 scfm)		1300 m ³ /min (45,900 scfm)
Supply voltage (see type plate)	230 / 115 VAC ± 10%, 50-60 Hz / 24 VDC ± 10%		
Power consumption	P < 8,0 VA (W)		
Recommended cable-jacket diameter	Ø 5,8 - 8,5 mm (0.23" - 0.34")		
Recommended wire cross-section	3x 0,75 - 1,5 mm ² / 5 x 0,25 mm ²		
Recommended fusing	0,5 A medium time-lag (AC) / 100 mA medium time-lag (DC)		
Protection class	IP 65		

¹⁾ Max. performance for ambient temperature 20°C. 50% r. h.

Dimensions

UFM-D30

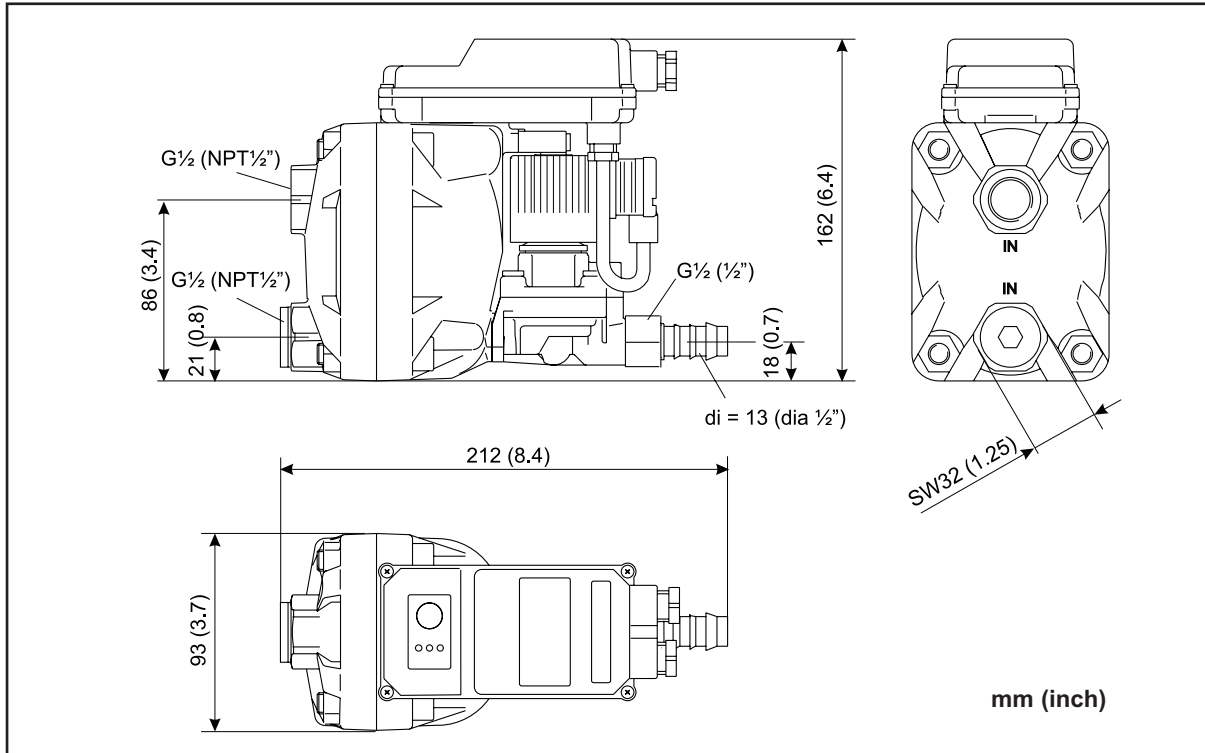

UFM-D30HP

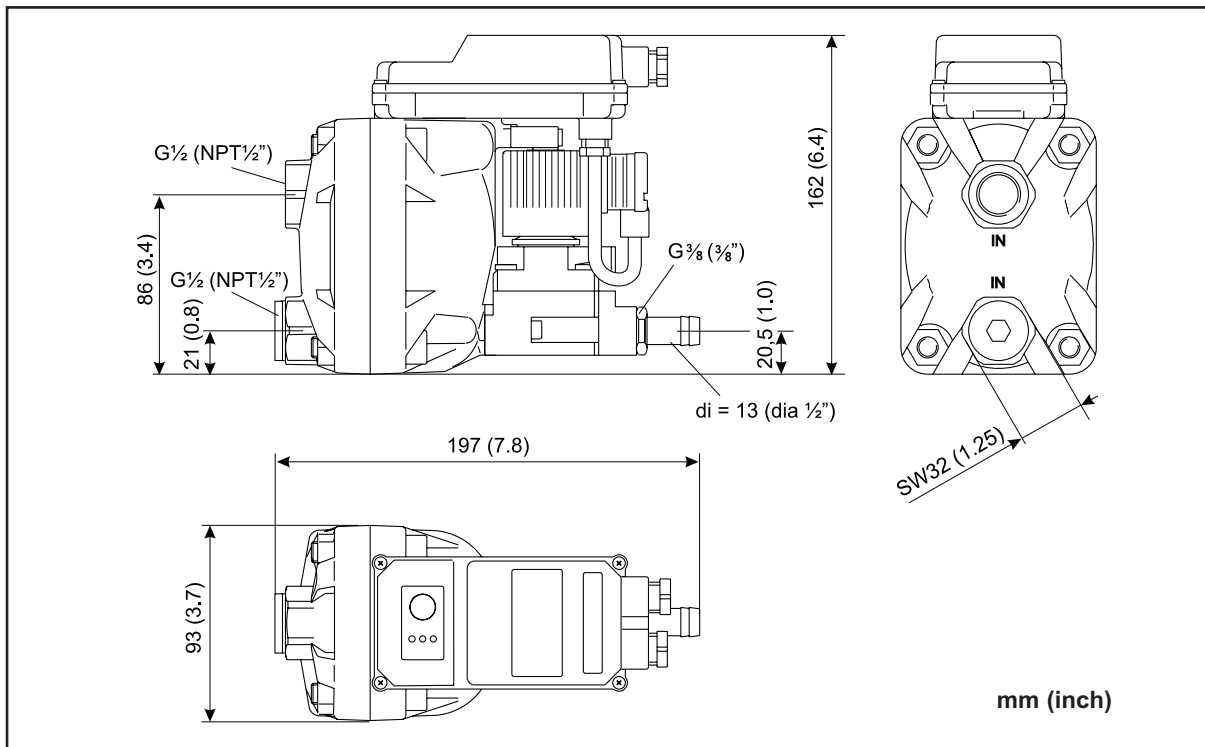

Dimensions

UFM-D130

